

# ECANZ CHALLENGE

## **INDUSTRIAL** **Preliminary Competition** **Project Information Guide**

**This document serves as a guide to a preliminary project of the ECANZ Challenge Electrical Apprentice of the year competition. It is intended to provide project information that is similar to what may be given to apprentices in the preliminaries for them to build.**

**This document cannot be copied in its entirety and/or partly, without written consent from ECANZ.**

**For information visit [www.ecanzchallenge.co.nz](http://www.ecanzchallenge.co.nz)**

**ECANZ  
CHALLENGE**

Copyright 2007

# COMPETITOR TASK LIST

## Non Hazardous area - Mixing Room Simulation

### Project One - design

Small mixing rooms, common in many New Zealand manufacturing businesses can be required to have air extraction systems to purge any contaminated air. The air extraction system in this project is required to run for 15 minutes prior to the energisation of any other electrical equipment in the room.

Your task is to design an electrical schematic diagram for a small mixing room.

### Considerations

1. Your diagram must show both the power/main circuit and the control circuit including incoming lines, neutral and earth.
2. You must use current IEC symbols, as mentioned in previous correspondence.

### Process

1. The mixing room is completely isolated from the electrical supply by a 40 amp, 3-phase isolator.
2. The 3-phase extraction system motor is protected by both short circuit and overcurrent protection:
  - Short circuit protection is provided by a circuit breaker rated at 16 amps
  - The motor is rated at 7.5 kW. Calculate the overcurrent setting and include it on your diagram.
3. The mixing room electrical system is energised by a start button and de-energised by a stop button.
4. Pressing the start button energises relay R1.
5. R1 deenergises an OFF lamp and energises an ON lamp, as well as an extraction system motor contactor C1 and ON-delay timer, T1.
6. R1 remains energised after the START button is released.
7. After 15 minutes, T1 energises contactor C2.
8. C2 energises a bulkhead light circuit and a single phase stirrer motor.
9. The control circuit is protected by a 6 amp circuit breaker.  
The bulkhead light circuit and the paint stirrer are protected by separate 10 amp circuit breakers.

### Project Two - build, test and install

Please note; depending on the complexity of the project, some years in the prelims the competitor may not be required to both design and build but only build.

# COMPETITION RULES

1. Appropriate safety clothing must be worn.
2. Covered footwear must be worn, preferably safety boots.
3. Earmuffs and safety glasses must be worn when required.
4. Wandering around other competitors work areas and discussing the project with other competitors is not permitted.
5. Smoking is not permitted inside competitor's area.
6. Radios are not permitted.
7. Should any project equipment be faulty extra time will be provided. The amount of extra time will be determined by the Chief Judge.
8. Non-compliance with these rules may result in disqualification.
9. If unsure, ask.

## NOTES for COMPETITORS

- All lighting points will be wired with an earthing conductor.
- The field wiring to the lighting circuits shall be re-designed to avoid unnecessary runs to the field devices.
- Competitors will provide the judges with an "as-built" wiring diagram for the purposes of marking.
- Offsets are required for all conduit entering the Distribution Board, Control Panel and other appropriate fittings. Offsets are not required for the mounting blocks or end boxes.
- Plain-to-screw adapters are not required for the conduits entering the mounting blocks.
- All trunking must be correctly mitred (joiners joint acceptable).
- All MCB wiring within the Distribution Board and Control Panel shall be min 2.5mm<sup>2</sup>.
- MCBs shall be ring fed.

# COMPETITION AREAS

Competition areas are open to view by the public and other competitors. Competitors shall not, however, examine other competitors work at close quarters during the competition.

***SAFETY  
IS ESSENTIAL***

## WIRING DIAGRAM (issued in project two)

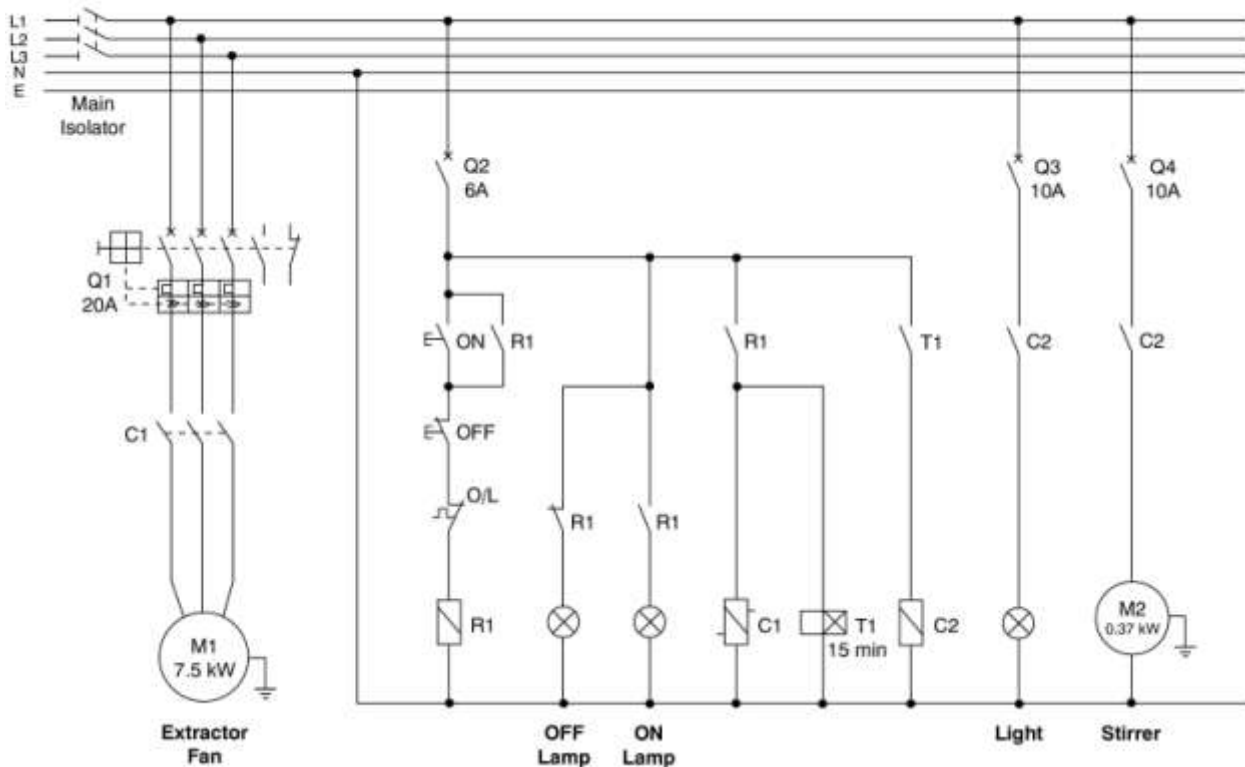

**ECANZ  
CHALLENGE**

Copyright 2007

# INSTALLATION DIAGRAM

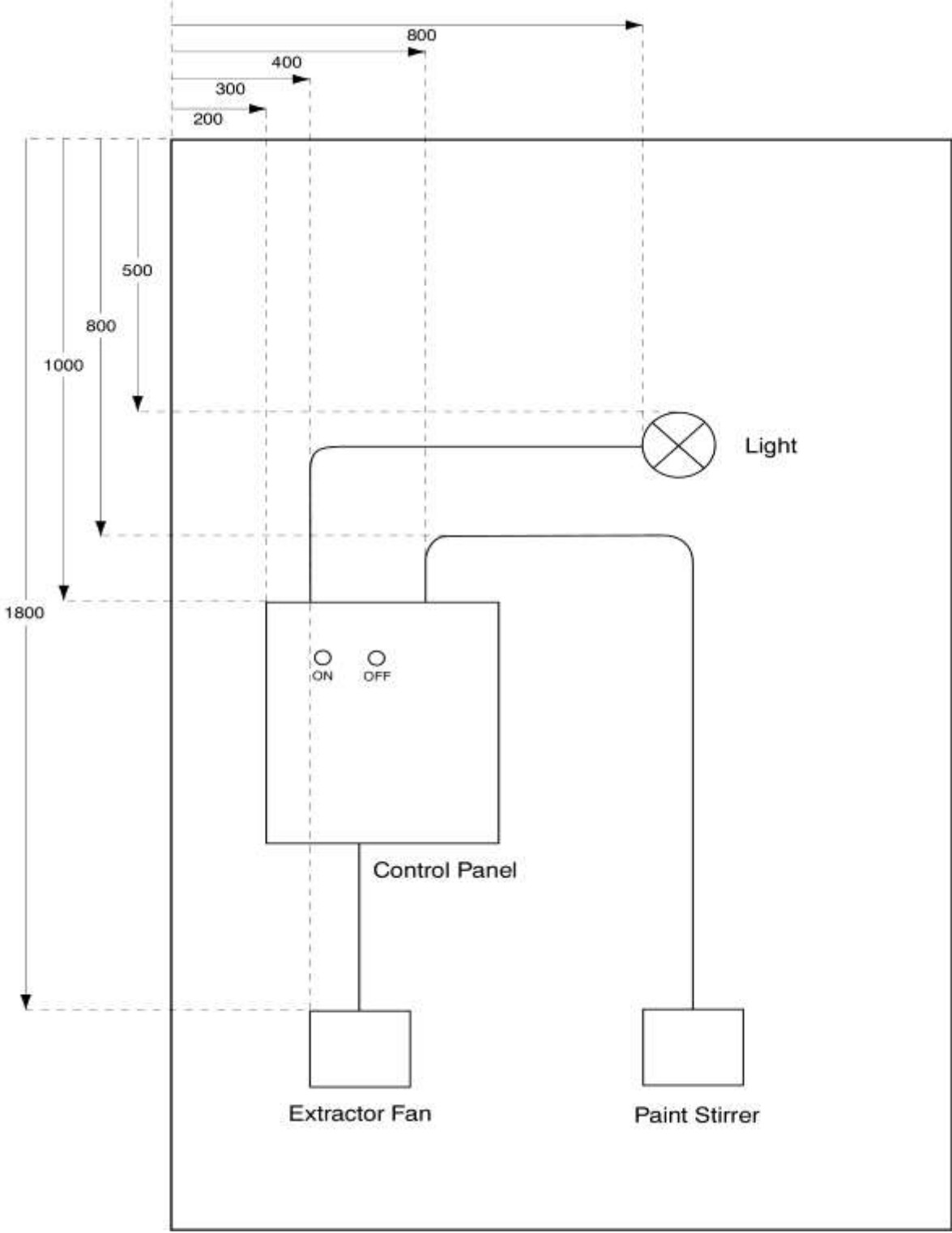

## **TEST REPORT (not shown)**

## **MATERIAL LIST (not shown)**

## **RECOMMENDED TOOL LIST**

- 1 Electricians Pliers
- 2 Side Cutters
- 3 Long Nose Pliers
- 4 Measuring Tape
- 5 Measuring Ruler
- 6 Level
- 7 Chalk Line
- 8 Set Square
- 9 Pocket Knife
- 10 Hacksaw
- 11 Bending Springs (20/25mm)
- 12 Hammer
- 13 Battery Drill with charger, spare battery and drill bits
- 14 Adjustable Spanner
- 15 Polygrips
- 16 Screwdrivers: Philips, flat and square drive
- 17 Reamer
- 18 Flat File
- 19 Round File
- 20 Half-Round File
- 21 Centre Punch
- 22 Holesaw Set
- 23 Pen, pencil, highlighter
- 24 Toolbox
- 25 Crimp Tool
- 26 Draw Wire
- 27 Cable Strippers
- 28 Safety Goggles, safety glasses, ear plugs
- 29 Spirit Level
- 30 Test Equipment (multimeter)
- 31 Insulation Resistance Tester